

GOLDBELL

Model SUPER-SS

Fully stainless steel check weighing scale



Features:

- ❑ Main feature: sealed circuit panel, loadcell & charger.
- ❑ Load cell is Water-proof protected.
- ❑ Stainless steel housing.
- ❑ Red LED display
- ❑ Platform size: 23cm x 19cm.
- ❑ Counting function with 4 measuring units
- ❑ Stability function setting
- ❑ Built-in rechargeable battery
- ❑ The protection grade is specified as IP67.
- ❑ Optional: RS232/485 communication interface

Capacity & Accuracy:

- ❑ 3kg x 0,2g
- ❑ 6kg x 0,5g
- ❑ 15kg x 1g
- ❑ 30kg x 2g

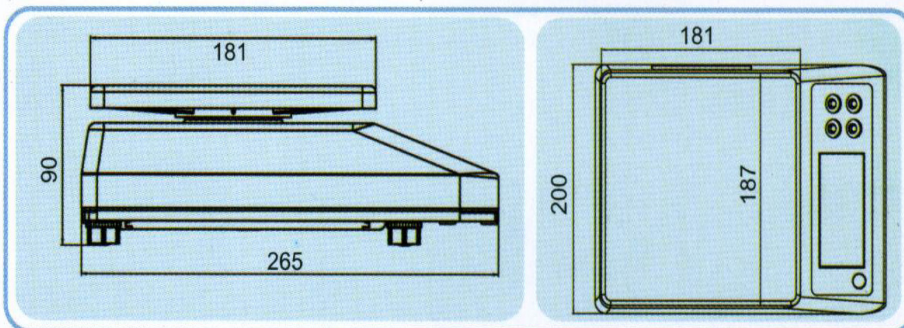

**Waterproof loadcell
protected**